

ICS08 3-wire DC



Miniaturized proximity inductive sensors



Benefits

- **A complete family.** Available in M8 male thread robust stainless steel housings with an operating distance of 1 to 4 mm.
- **Easy to install.** Both flush and non-flush construction are available. The user can choose between short and long body housings in 2 m PVC cable or M8-disconnect plug versions.
- **High precision.** The onboard advanced microcontroller ensures better stability with respect to environmental influences, with highly repeatable measurements between -25 and +80°C.
- **Integrated diagnostic function** with flashing LED in the event of a short circuit or overload
- **Easy customization to specific OEM requests:** different cable lengths and materials, special labelling, customized pig-tail solutions with special cables and connectors are possible on request.

Description

ICS08 series represents the optimal solution for industrial automation equipment in applications where space is limited, but long switching distance is needed, including tool-selection and textile machines. The advanced electronics is encapsulated in a robust stainless steel housing. The availability of the M8-plug and 2m-PVC cable connection in short or long housing construction allows flexible mounting. Output is open collector NPN or PNP transistors.

Applications

- Non contact detection of metal objects in general position-sensing and presence-sensing in industrial applications
- Particularly suitable for rotational speed monitoring thanks to the high operating frequency

References

Order code

 ICS08

Enter the code option instead of

Code	Option	Description
I	-	Inductive sensor
C	-	Cylindrical housing with threaded barrel
S	-	Stainless steel housing
08	-	M8 housing
<input type="checkbox"/>	S30	Short housing with thread barrel of 30 mm
<input type="checkbox"/>	L45	Long housing with thread length of 45 mm
<input type="checkbox"/>	F	Flush
<input type="checkbox"/>	N	Non-flush
<input type="checkbox"/>	01	Sensing distance 1mm
<input type="checkbox"/>	02	Sensing distance 2mm
<input type="checkbox"/>	04	Sensing distance 4mm
<input type="checkbox"/>	NO	NPN – normally open output
<input type="checkbox"/>	NC	NPN – normally closed output
<input type="checkbox"/>	PO	PNP – normally open output
<input type="checkbox"/>	PC	PNP – normally closed output
<input type="checkbox"/>	M5	M8 plug
<input type="checkbox"/>	(null)	2 m PVC cable

Additional characters can be used for customized versions.

Selection guide

M8 standard range, short housing

Con- nec- tion	Rated operating distance Sn	Dete- ction princi- ple	Ordering no. NPN, Normally open	Ordering no. PNP, Normally open	Ordering no. NPN, Normally closed	Ordering no. PNP, Normally closed
Cable	1 mm	Flush	ICS08S30F01NO	ICS08S30F01PO	ICS08S30F01NC	ICS08S30F01PC
Plug			ICS08S30F01NOM5	ICS08S30F01POM5	ICS08S30F01NCM5	ICS08S30F01PCM5
Cable	2 mm	Non- flush	ICS08S30N02NO	ICS08S30N02PO	ICS08S30N02NC	ICS08S30N02PC
Plug			ICS08S30N02NOM5	ICS08S30N02POM5	ICS08S30N02NCM5	ICS08S30N02PCM5

M8 standard range, long housing

Con- nec- tion	Rated operating distance Sn	Dete- ction princi- ple	Ordering no. NPN, Normally open	Ordering no. PNP, Normally open	Ordering no. NPN, Normally closed	Ordering no. PNP, Normally closed
Cable	1 mm	Flush	ICS08L45F01NO	ICS08L45F01PO	ICS08L45F01NC	ICS08L45F01PC
Plug			ICS08L45F01NOM5	ICS08L45F01POM5	ICS08L45F01NCM5	ICS08L45F01PCM5
Cable	2 mm	Non- flush	ICS08L45N02NO	ICS08L45N02PO	ICS08L45N02NC	ICS08L45N02PC
Plug			ICS08L45N02NOM5	ICS08L45N02POM5	ICS08L45N02NCM5	ICS08L45N02PCM5

M8 extended range, short housing

Con- nec- tion	Rated operating distance Sn	Dete- ction princi- ple	Ordering no. NPN, Normally open	Ordering no. PNP, Normally open	Ordering no. NPN, Normally closed	Ordering no. PNP, Normally closed
Cable	2 mm	Flush	ICS08S30F02NO	ICS08S30F02PO	ICS08S30F02NC	ICS08S30F02PC
Plug			ICS08S30F02NOM5	ICS08S30F02POM5	ICS08S30F02NCM5	ICS08S30F02PCM5
Cable	4 mm	Non- flush	ICS08S30N04NO	ICS08S30N04PO	ICS08S30N04NC	ICS08S30N04PC
Plug			ICS08S30N04NOM5	ICS08S30N04POM5	ICS08S30N04NCM5	ICS08S30N04PCM5

M8 extended range, long housing

Con- nec- tion	Rated operating distance Sn	Dete- ction princi- ple	Ordering no. NPN, Normally open	Ordering no. PNP, Normally open	Ordering no. NPN, Normally closed	Ordering no. PNP, Normally closed
Cable	2 mm	Flush	ICS08L45F02NO	ICS08L45F02PO	ICS08L45F02NC	ICS08L45F02PC
Plug			ICS08L45F02NOM5	ICS08L45F02POM5	ICS08L45F02NCM5	ICS08L45F02PCM5
Cable	4 mm	Non- flush	ICS08L45N04NO	ICS08L45N04PO	ICS08L45N04NC	ICS08L45N04PC
Plug			ICS08L45N04NOM5	ICS08L45N04POM5	ICS08L45N04NCM5	ICS08L45N04PCM5

Structure

ICS08

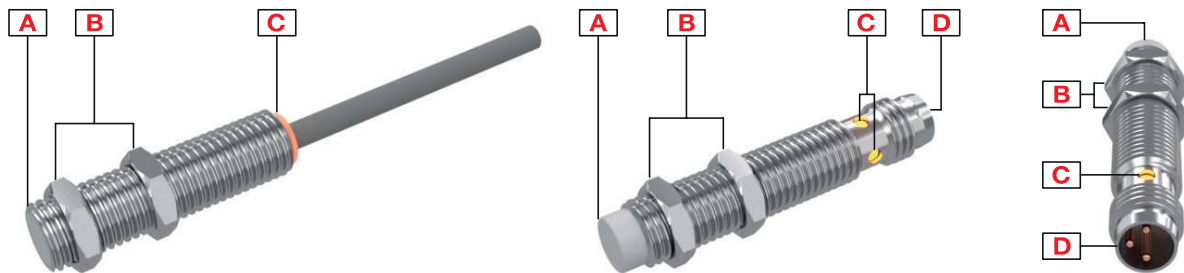

Element	Component	Function
A	Sensing face	Flush or non-flush
B	2 nuts	For sensor mounting
C	LED	Yellow LED: Output flashing: short circuit or overload indication
D	M8, 3 pin, male connector	For plug versions only

Sensing

Detection

Rated operating distance S_n	Standard range: 1 mm (flush) and 2 mm (non-flush) Extended range: 2 mm (flush) and 4mm (non-flush)
Reference target	The operating distance is measured according to IEC 60947-5-2, using a standard target moving axially. This target is square shape 1 mm thickness, made of steel e.g. type Fe 360 as defined in ISO 630 and it shall be of the rolled finish. The length of the side of the square is equal to – the diameter of the circle inscribed on the active surface of the sensing face, or – three times the rated operating distance S_n whichever is greater
Assured operating sensing distance (S_a)	$0 \leq S_a \leq 0.81 \times S_n$ (e.g. with S_n of 2 mm, S_a is 0 ... 1.62 mm)
Effective operating distance (S_r)	$0.9 \times S_n \leq S_r \leq 1.1 \times S_n$
Usable operating distance (S_u)	$0.9 \times S_r \leq S_u \leq 1.1 \times S_r$
Temperature drift	$\leq \pm 10\%$
Hysteresis (H)	1...20%

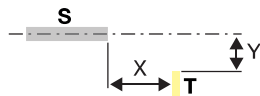

S: sensor
T: target

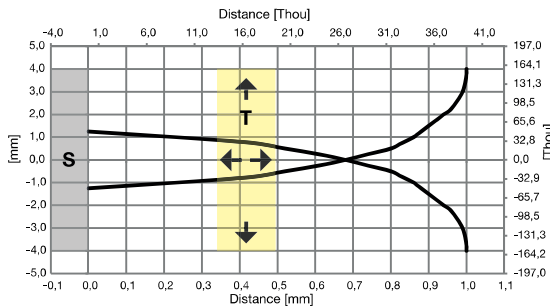

Fig. 1 Flush, 1mm

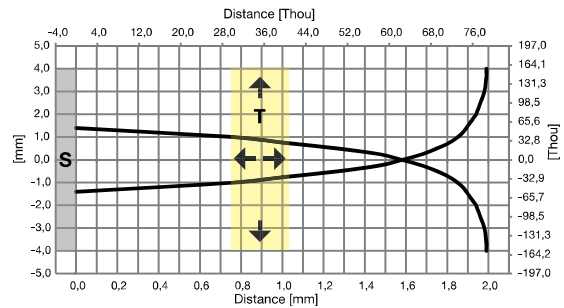

Fig. 2 Flush, 2mm

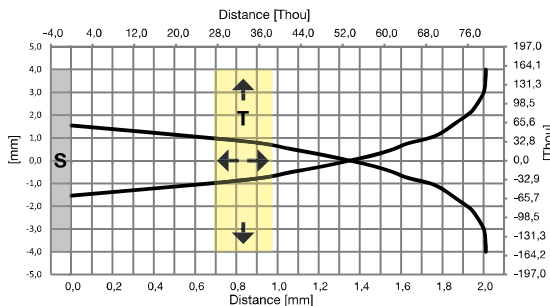

Fig. 3 Non-flush, 2mm

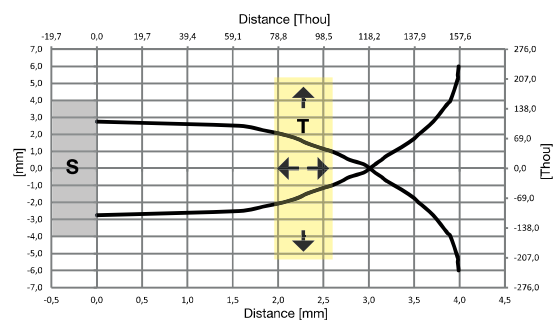

Fig. 4 Non-flush, 4mm

Correction factors

The specific operating distance S_n refers to defined measuring conditions. The following data have to be considered as general guidelines.

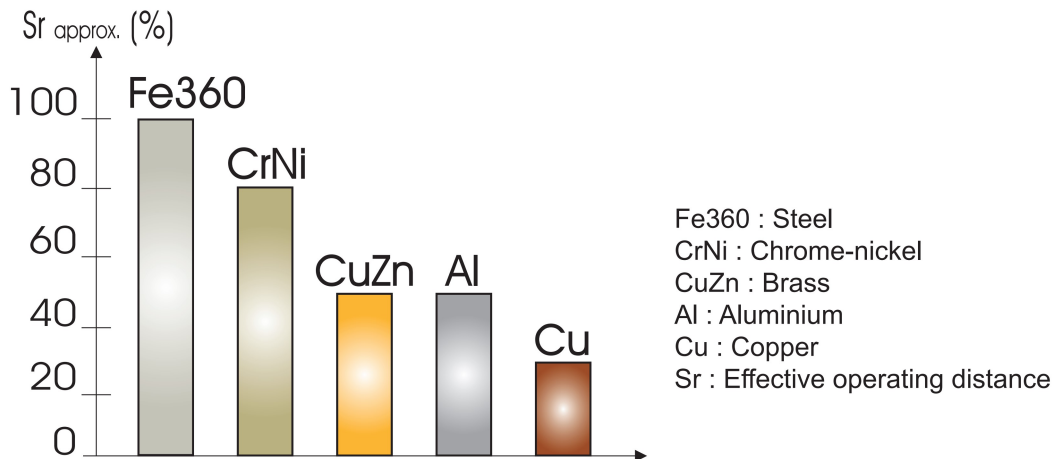

Fig. 5 The rated operating distance is reduced by the use of metals and alloys other than Fe360. The most important reduction factors for inductive proximity sensors are shown in the figure.

Accuracy

Repeat accuracy (R)	≤ 5%
---------------------	------

Features

Power Supply

Rated operational voltage (U_o)	10 to 36 VDC (ripple included)
Ripple (U_{pp})	≤ 10%
No load supply current (I_o)	≤ 16 mA
Power ON delay (t_o)	≤ 20 ms

Outputs

Output functions	NPN or PNP by sensor type
Output configuration	N.O. and N.C. by sensor type
Output current (I_o)	≤ 200 mA @ 50°C (122°F); ≤ 150 mA @ 50°C...80°C (122°F...176°F)
OFF-state current (I_o)	≤ 50 μA
Voltage drop (U_d)	Max. 1.6 VDC @ 200 mA
Protection	Short-circuit, reverse polarity, transients and overload
Voltage transient	1 kV/0.5 J

Response times

Operating frequency (f)	≤ 2 KHz
-------------------------	---------

Indication



Standard IO mode:

Yellow LED	Output	Description
OFF	OFF	N.O. output, target not present N.C. output, target present
ON	ON	N.O. output, target present N.C. output, target not present
Blinking	f: 2Hz	Short-circuit or overload

Environmental

Ambient temperature	Operating: -25° to +80°C (-13° to +176°F)	
	Storage: -30° to +80°C (-22° to +176°F)	
Ambient humidity	Operating: 35% to 95%	
	Storage: 35% to 95%	
Vibration	10 to 55 Hz, amplitude 1.0 mm; sweep cycle 5 min; in X, Y and Z direction	IEC 60068-2-6
Shock	30 G /11 ms. 10 shocks in X, Y and Z direction	IEC 60068-2-27
Degree of protection	IP67	IEC 60529; EN 60947-1

Compatibility and conformity

EMC protection IEC 60947-5-2	IEC 61000-4-2 Electrostatic discharge	8 kV air discharge 4 kV contact discharge
	IEC 61000-4-3 Radiated radiofrequency	3 V/m
	IEC 61000-4-4 Burst immunity	2 kV
	IEC 61000-4-6 Conducted radio frequency	3 V
	IEC 61000-4-8 Power frequency magnetic fields	30 A/m
MTTF _d	2914 years @ 50°C (122°F)	
Approvals	 	
	CCC is not required for products rated ≤ 36 V	

Mechanical data

Weight (including 2 nuts and the packaging) max.	Cable version: short, flush: 44.8g; short, non-flush: 44.9g; long, flush: 47g; long, non-flush: 47.1g; Plug version: short, flush: 16g; short, non-flush: 16.1g; long, flush: 18.4g; long, non-flush: 18.5g.
Mounting	Flush mountable or non-flush mountable
Material	Housing: stainless steel AISI304 Front cap: Grey thermoplastic polyester
Max tightening torque	7 Nm

Electrical connection

Cable	2m, 3 x 0.14 mm ² , Ø3.2 mm, PVC, grey, oil proof, laser write
Plug	M8 x 1 quick disconnect, 3 pin, male connector

Connection Diagrams

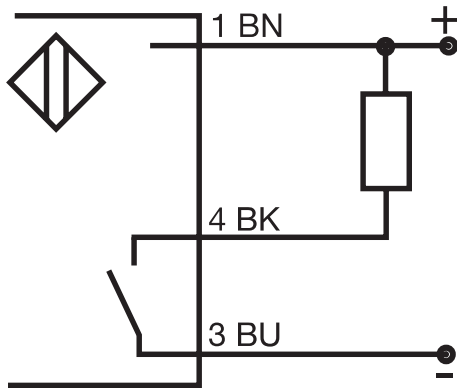

Fig. 6 NPN - Normally open

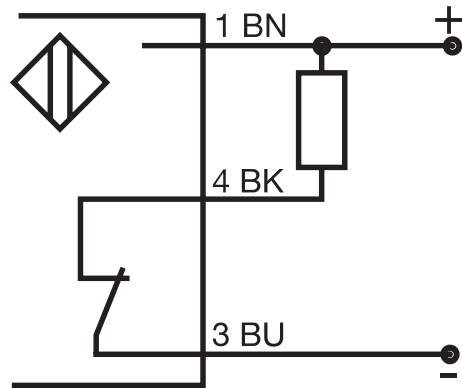

Fig. 7 NPN - Normally closed

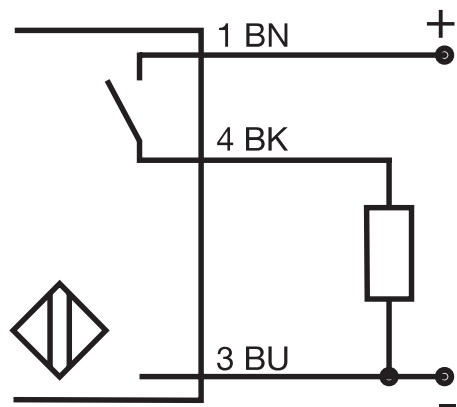

Fig. 8 PNP - Normally open

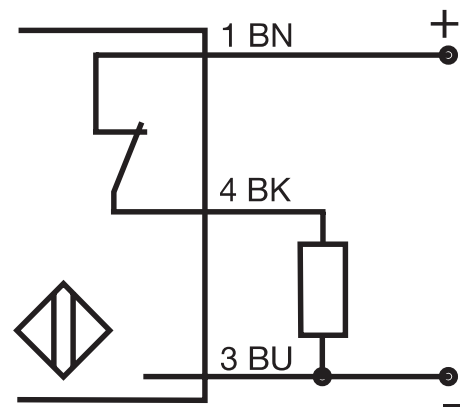

Fig. 9 PNP - Normally closed

Colour code		
BN: brown	BK: black	BU: blue

Dimensions [mm]

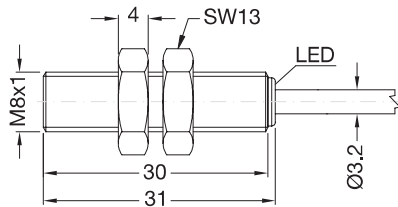

Fig. 10 Short body, flush version, cable

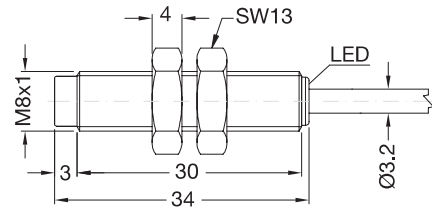

Fig. 11 Short body, non-flush version, cable

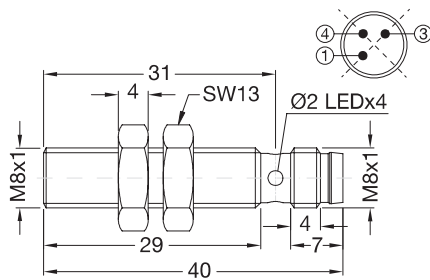

Fig. 12 Short body, flush version, plug

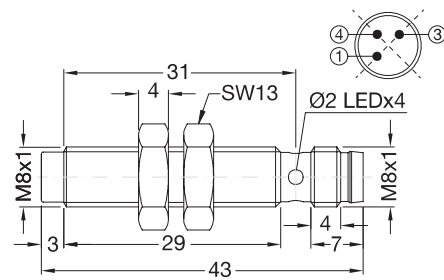

Fig. 13 Short body, non-flush version, plug

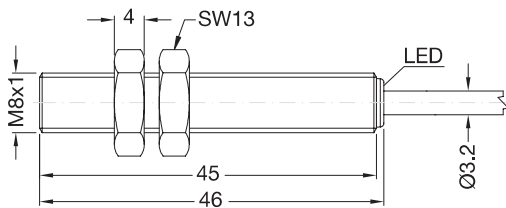

Fig. 14 Long body, flush version, cable

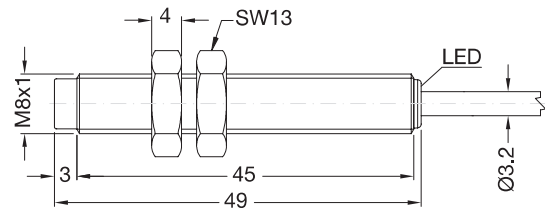

Fig. 15 Long body, non-flush version, cable

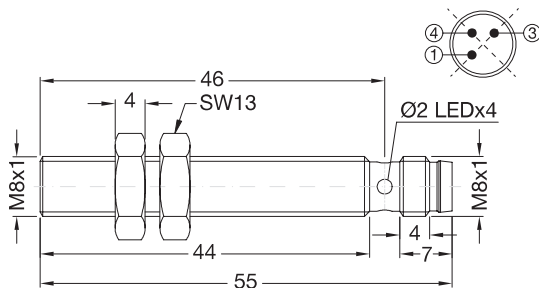

Fig. 16 Long body, flush version, plug

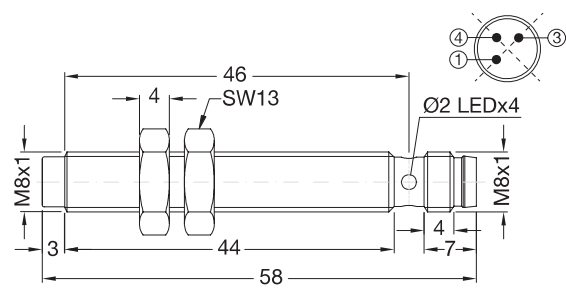

Fig. 17 Long body, non-flush version, plug

Installation

M8 flush

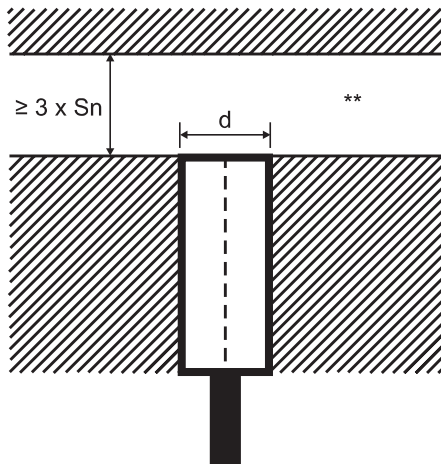

Fig. 18 Flush sensor, when installed in damping material

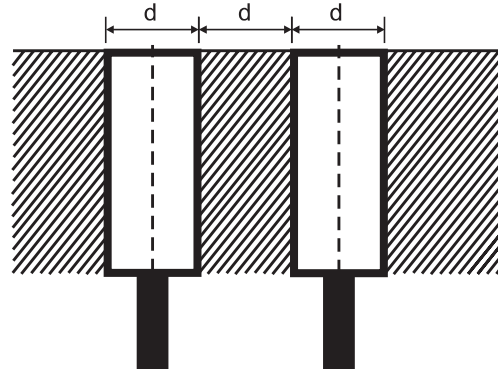

Fig. 19 Flush sensors, when installed together in damping material

M8 non-flush

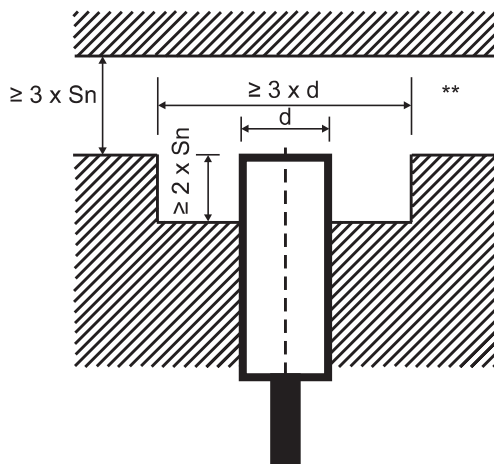

Fig. 20 Non-flush sensor, when installed in damping material

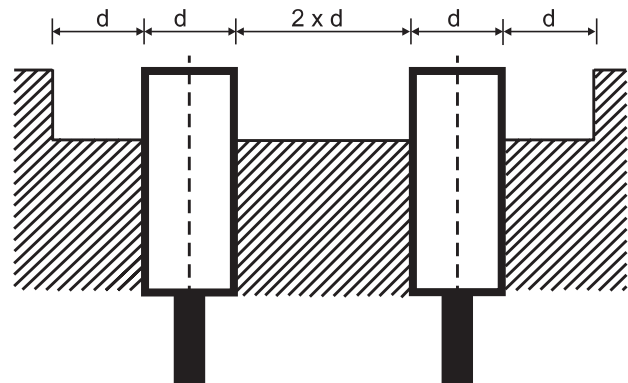

Fig. 21 Non-flush sensors, when installed together in damping material

Sensors installed opposite each other

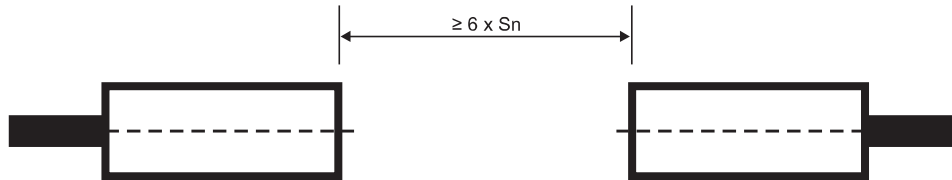

Fig. 22 For sensors installed opposite each other, a minimum space of $6 \times S_n$ (the nominal sensing distance) must be observed

** Free zone or non-damping material

S_n : nominal sensing distance

d: sensor diameter: 8 mm

Delivery contents and compatible components



Delivery contents

- Inductive proximity switch
- 2 fixing nuts
- Packaging: plastic bag

CARLO GAVAZZI compatible components

- Mounting bracket AMB8... to be purchased separately
- Connector type: CONB53... series to be purchased separately

Further reading

Information	Where to find it	QR
Mounting brackets	http://www.productselection.net/Pdf/UK/AMB8_30.pdf	
Connectors	http://www.productselection.net/Pdf/UK/CONB5.pdf	



COPYRIGHT ©2020

Content subject to change. Download the PDF: www.gavazziautomation.com